

**Kiwa GmbH**  
Bautest Augsburg  
Finkenweg 7  
86368 Gersthofen

Kiwa GmbH, Finkenweg 7, 86368 Gersthofen

Hauff-Technik GmbH & Co. KG  
Robert-Bosch-Straße 9  
89428 Hermaringen

T: +49 (0) 821 72024 - 0  
F: +49 (0) 821 72024 - 40  
E: [Infokiwa Augsburg@kiwa.de](mailto:Infokiwa Augsburg@kiwa.de)

[www.kiwa.de](http://www.kiwa.de)

**Project / Plant:** Water tightness test of the single building entry system  
Hauff ESH PolySafe with the outer sealing element module 1.2 installed in  
a wall sleeve of a test block with exterior waterproofing PCI Pecimor 2K  
(waterproofing class W2.1E according to DIN 18533-1)

**Order date:** 22 November 2017

**Product description:** Single building entry system Hauff ESH PolySafe with the outer sealing  
element module 1.2

**Order:** Water tightness test  $\geq 1,0$  bar for 28 days

**Number of samples / tests:** 1 test

**Sampling:** on: - / by: Applicant

**Date of delivery:** 22 November 2017

**Testing period:** 22 November - 20 December 2017

**Contact:** B. Eng. David Röck  
Tel. +49 821 72024-14

**Number of annexes:** The test report contains 1 annex

**Remark:** Translation of Test Report A1742021-01,  
11 June 2018

Gersthofen, 11 June 2018  
rö/cl

p. p.

  
Dipl.-Ing. (FH) Kerstin Schedl  
- Project manager -

p. p.

  
Jörg Bölzle  
- Project manager -

The test results relate only on the items tested. Without the written approval of the testing laboratory, a duplication in extracts of the test report is not permitted.

Geschäftsführer: Prof. Dr. Roland Hüttl  
Amtsgericht Hamburg, HRB 130568, St.Nr.: 46/736/03268



## CONTENTS

	Page
<b>1. General</b> .....	<b>3</b>
<b>2. References</b> .....	<b>3</b>
<b>3. Test procedure</b> .....	<b>4</b>
3.1 Test preparation (Hauff Technik GmbH & Co. KG) .....	4
3.2 Water tightness test (Kiwa GmbH).....	5
<b>4. Test results</b> .....	<b>7</b>
<b>5. Summary</b> .....	<b>7</b>
<b>6. Calibration certificate</b> .....	<b>8</b>

## 1. General

Kiwa GmbH, Bautest Augsburg, was contracted by Hauff-Technik GmbH & Co. KG to test the water tightness of the single building entry system Hauff ESH PolySafe with the outer sealing element module 1.2 [1] installed in a test block with the exterior waterproofing polymer modified bituminous coating (PMBC) PCI Pecimor 2K (waterproofing class W2.1E according to DIN 18533-1 [2] and DIN 18533-3 [3]).

Therefore Hauff-Technik GmbH & Co. KG delivered the test block with the already installed single building entry system Hauff ESH PolySafe with the outer sealing element module 1.2 together with the components for the test setup to our test laboratory in Gersthofen, Germany. The surface of the test block which was charged with water pressure was already finished with exterior waterproofing PMBC PCI Pecimor 2K [4] according to DIN EN 15814 [5]. The assembly of the test setup was performed by an employee of Hauff-Technik GmbH & Co. KG (see Figure 1).

To test exclusively the sealing function between the PMBC and the single building entry system Hauff ESH PolySafe with the outer sealing element module 1.2 the cast in wall sleeve was cut longitudinal to create a gap for possibly penetrating water.

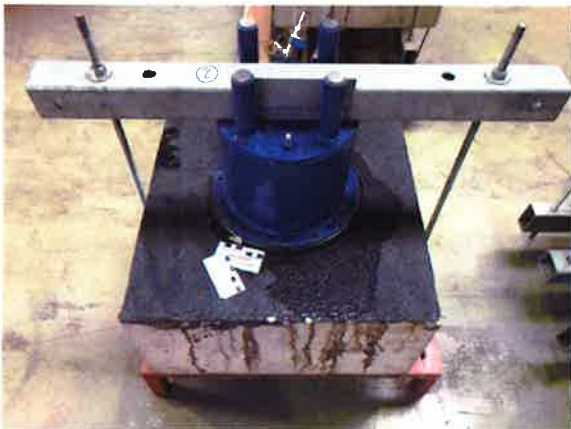

Figure 1. Assembled test setup.

## 2. References

- [1] Hauff-Technik GmbH & Co. KG - „Assembly instruction ESH PolySafe - single building entry systems for buildings with a basement“. Rev.: 00/2017-11-09“.
- [2] DIN 18533-1. Waterproofing of elements in contact with soil - Part 1: Requirements and principles for design and execution. Edition July 2017.
- [3] DIN 18533-3. Waterproofing of elements in contact with soil - Part 3: Waterproofing with liquid-applied waterproofing materials. Edition July 2017.
- [4] PCI technical data sheet 302 - „Bitumen thick coating PCI Pecimor® for external basement walls and foundations. Edition August 2017.
- [5] DIN EN 15814. Polymer modified bituminous thick coatings for waterproofing - Definitions and requirements. Edition March 2015.
- [6] WIK A Alexander Wiegand SE & CO. KG - “Inspection certificate according to EN 10204 - 3.1. Order No. 22392920/3“.

### 3. Test procedure

#### 3.1 Test preparation (Hauff Technik GmbH & Co. KG)

The assembly of the test setup was performed by the manufacturer (Hauff Technik GmbH & Co. KG) of the single building entry system at Kiwa GmbH in Gersthofen, Germany. According to information given by the manufacturer the test setup was assembled as follows:

A wall sleeve was cut longitudinal to create a continued water gap before it was cast in a test block with concrete strength C20/25.

The surface of the test block which was charged with water pressure (this corresponds to the outside of a building) was treated with two layers of the PMBC PCI Pecimor 2K [4] according to DIN EN 15814 [5] to create an exterior waterproofing.

After hardening of the exterior waterproofing the single building entry system ESH PolySafe was set in the wall sleeve through the side of the test block which is not charged with water pressure (see Figure 2 - left) until the flange of the single building entry was flush with the concrete surface. After that the two holes ( $\varnothing 10$  mm, borehole depth 80 mm) were drilled, the additional tabs were installed and then doweled with a torque of max. 20 Nm (see Figure 2 - right).

After aligning the hexagonal contour of the flange the four internal hex screws of the inner seal were tightened (see Figure 3 - left) crosswise until the control pins were flush with the front panel or a torque of max. 6 Nm was reached. Then the appropriate black screw protection caps were attached (see Figure 3 - right).

The ESH PolySafe outer sealing element module 1.2 was pushed over the sleeve pipe of the single building entry system as far as possible against the side of the test block which is charged with water pressure (see Figure 4 - left). Thereon the four internal hex screws of the ESH PolySafe outer sealing element module 1.2 were tighten crosswise until a torque of 6 Nm was reached (see Figure 4 - right).

After sealing the sleeve pipe of the single building entry ESH PolySafe with a blind plug at the side of the concrete test block which is charged with water pressure a testing cylinder with pressure reducer, manometer and an EPDM sealing was attached above the sealing system. The sealing of the testing cylinder was performed with the help of the EPDM sealing and the clamping pressure of the threaded rods and the security bar.

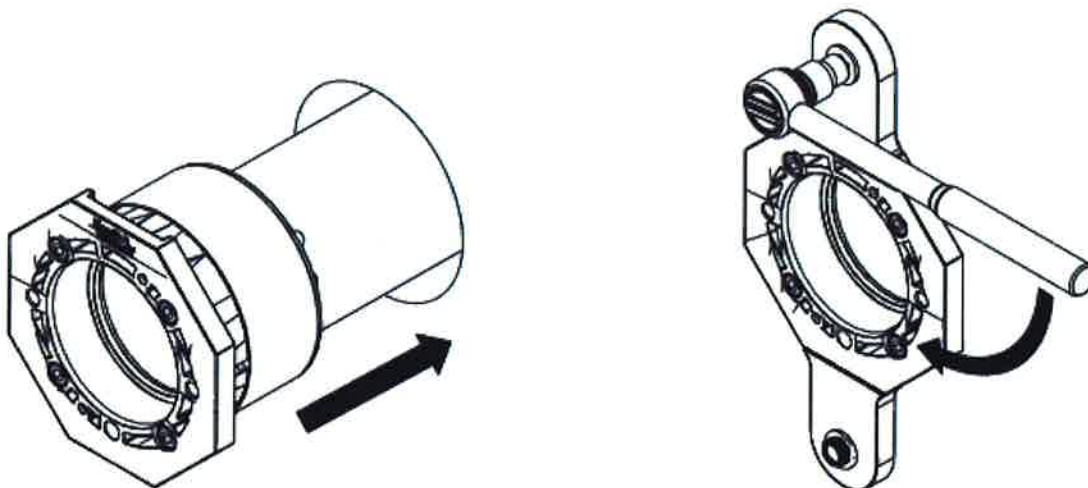

Figure 2. Pushing the single building entry ESH PolySafe into the wall sleeve (left) and tightening with the dowels after installing the additional tabs (right) (picture of the manufacturer).

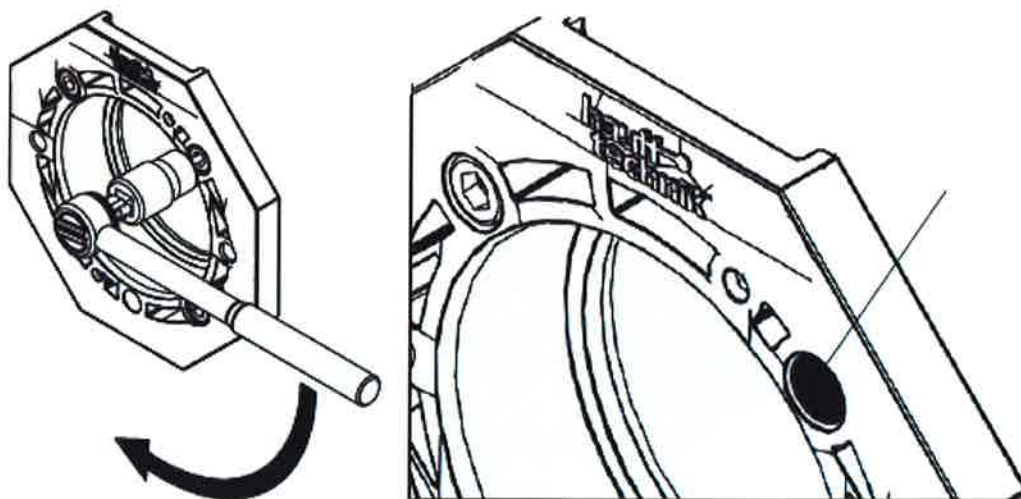

Figure 3. Tightening the four internal hex screws of the inner seal (left) and attaching the appropriate black screw protection caps (picture of the manufacturer).

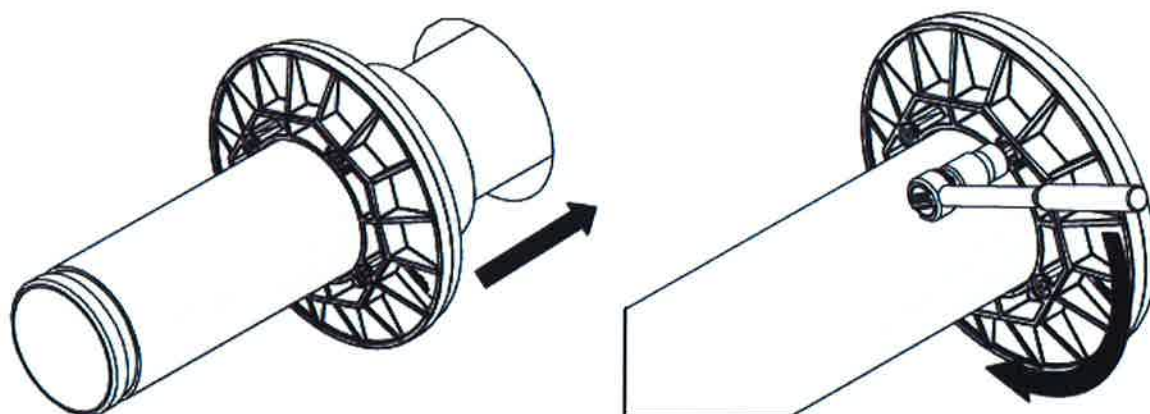

Figure 4. Installation of the ESH PolySafe outer sealing element module 1.2 over the sleeve pipe and tightening of the four internal hex screws of the outer sealing element module 1.2 (right) (picture of the manufacturer).

### 3.2 Water tightness test (Kiwa GmbH)

The test setup which was assembled by Hauff-Technik GmbH & Co. KG was built up in accordance to Section 3.1 with one manometer (see Figure 5).

A calibration of the assembled manometer (serial no. 54604157 [6]) was performed by WIKA Alexander Wiegand SE & Co. KG (see Section 6).

After prior consultation with the manufacturer the test of the water tightness with permanently attached water pressure was performed with  $\geq 1,0$  bar for 28 days.

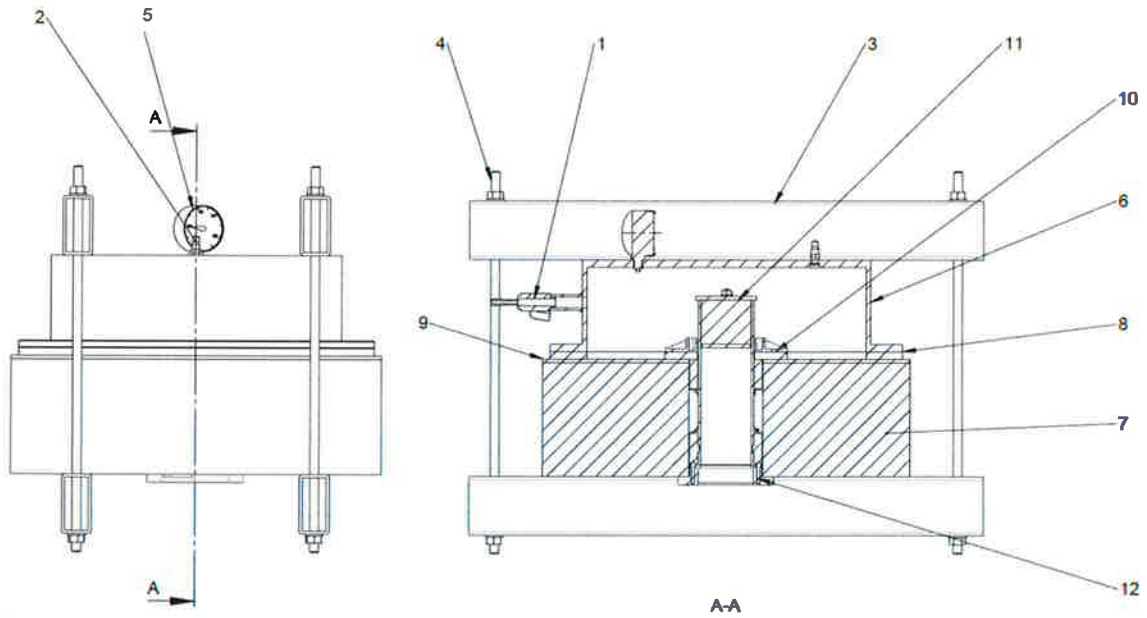

Position	Designation
1	stop valve
2	air bleed valve
3	security bar
4	threaded bolt M12 with shim and nut
5	pressure gauge manometer
6	test cylinder
7	touchstone
8	test cylinder seal
9	PMBC
10	ESH PolySafe outer sealing element
11	blind plug
12	ESH PolySafe basic variant with inner seal

Figure 5. Detail of the test setup - manufacturer's drawing.

#### 4. Test results

During the water tightness test no pressure drop as a result of leakages was detected (see Table 1). The test results can be seen at Figure A1 and Figure A2 attached in the annex.

Table 1. Results of the water tightness test.

Test specimen	Water pressure at the beginning of testing [bar]	Water pressure at the end of testing [bar]	Testing period [d]	Remark
ESH PolySafe	≥ 1,0	≥ 1,0	28	no pressure drop as a result of leakages

#### 5. Summary

*During the water tightness test of the single building entry system Hauff ESH PolySafe with the outer sealing element module 1.2 which was installed in a wall sleeve that was cast in a concrete test block with exterior waterproofing PMBC PCI Pecimor 2K according to DIN EN 15814 no pressure drop as a result of leakages was detected during the testing period of 28 days with a permanent attached water pressure of ≥ 1,0 bar.*

## 6. Calibration certificate

Wika Polska sp. z o.o. sp. k.

Inspection certificate according to EN 10204 - 3.1  
Abnahmeprüfzeugnis nach EN 10204 - 3.1



Page 1 / 2  
Seite

Customer: Haufl-Technik GmbH & Co. KG  
Kunde: Robert-Bosch-Strasse 9  
Hermmaringen 85548 DE

Certificate No: WC003867  
Zeugnis-Nr:  
Date: 2017-05-05  
Datum:

Customer Order No Kundenbestellnummer	175202179	Customer Part No Kunden Artikel-Nr	Order Date Bestelldatum	2017-03-23	
Order No / Item Auftrags-Nr / Pos	223929203 31977549	Part No Artikel-Nr	14225187		
Model Typ	111 10 063	Serial number Seriennummer	54804157	Scale range Anzeigebereich	0 - 6 bar rel
Class Klasse	2,50 %	Tag No Messstellen-Nr			
Reference Referenzgerät	CPG2500 0.01% IS-50 1 32.1 bar rel	Calibration No Kalibriernummer	SW 101-1 17 WP-L 17.04		

Result: Temperature 20 °C +/- 0.5 K  
Ergebnis: Temperatur

Test Item Prüfung	Standard Referenz	Measured Value Ableswert	Deviation rel. Abweichung	Correction Korrektur	Hydronic Hydrone
bar	bar	bar	bar	%	%
1.000	0.997	1.009	0.998	0.002	0.35
2.000	2.002	2.006	2.005	-0.005	0.11
3.000	3.028	3.018	3.023	-0.023	-0.17
4.000	4.013	4.027	4.020	-0.020	-0.22
6.000	6.008	6.008	6.008	-0.008	0.20

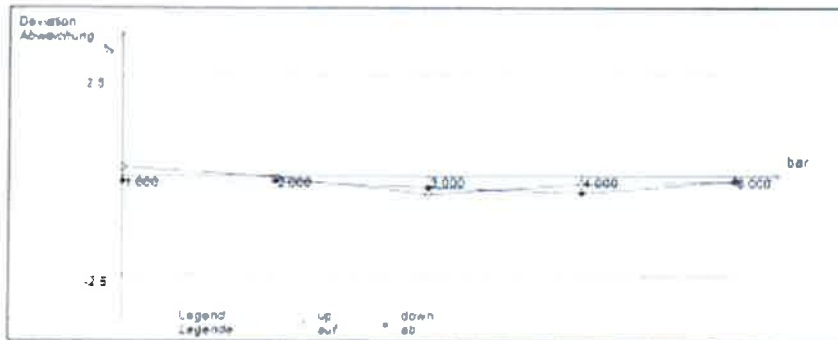

Wika Polska sp. z o.o. sp. k.  
ul. Legnicka 29/35  
87-800 Wodzisław  
Polska

Tel: +48 54 23 01 100  
Fax: +48 54 23 01 101  
info@wikapolska.pl  
www.wikapolska.pl

Wika Polska sp z o.o sp. k.

Inspection certificate according to EN 10204 - 3 1  
Abnahmeprüfzeugnis nach EN 10204 - 3 1



<b>Customer</b> <b>Kunde</b>	<b>Haufl Technik GmbH &amp; Co. KG</b> Robert Bosch Straße 9 Herrnaringen 89558 DE	<b>Page</b> <b>Seite</b>	2 / 2
		<b>Certificate No</b> <b>Zeugnis Nr</b>	WC003867
		<b>Date</b> <b>Datum</b>	2017-05-05

Object keeps the specification

Der Kalibriergegenstand hält die Fehlergrenzen nach Herstellerangaben ein

Calibration was carried out according to the following norm

Die Kalibrierung erfolgte auf der Grundlage der folgenden Norm

DIN EN 837-1

Remarks / Bemerkung

Inspection Representative

(N.C.)

Abnahmebeauftragter

Daniel Kotlewski

Examiner

Prüfer

J. Glodowski

This document was created automatically and needs no signature

Dieses Dokument wurde automatisch erstellt und gilt ohne Unterschrift

Wika Polska sp z o.o sp. k.  
ul. Łęska 29/35  
87-800 Włocławek  
Polska

Tel: +48 54 23-C1-100

Fax: +48 54 23-C1-101

info@wikapolska.pl

www.wikapolska.pl

Gersthofen, 11 June 2018



Figure A1. Water tightness test with  $\geq 1,0$  bar water filled test cylinder (manometer at the beginning of testing on 22.11.2017).



Figure A2. Water tightness test with  $\geq 1,0$  bar water filled test cylinder (manometer after 28 days on 20.12.2017).